

See included template for door prep specifications

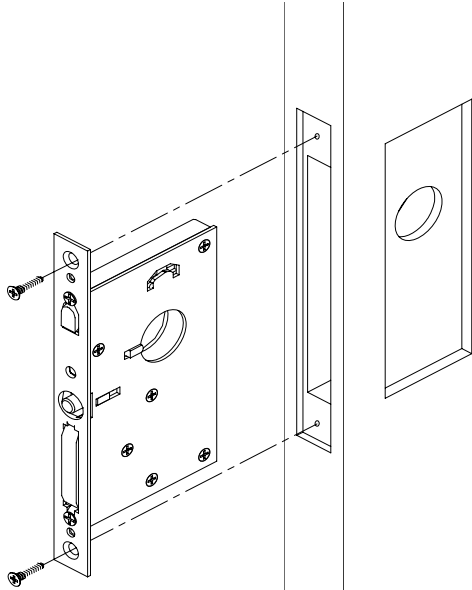

Install lock body into door.

Inside Trim

Thread Drive Bar Cylinder into lock body.
NOTE: Drive Bar Socket must be positioned up.

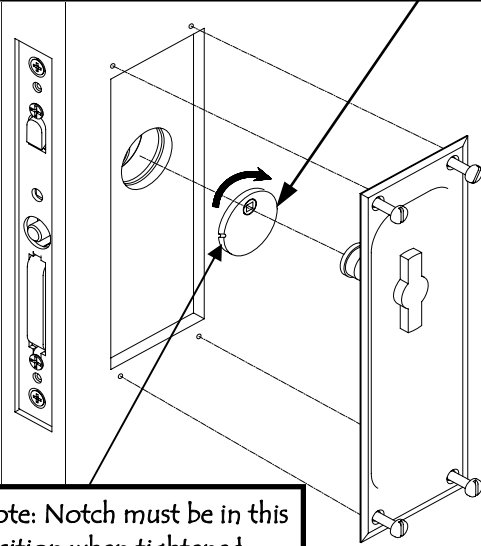

Note: Notch must be in this position when tightened.

Drill pilot holes for wood screws (provided).

Outside Trim

Note: Key Cylinder must be in an upward position when tightened.

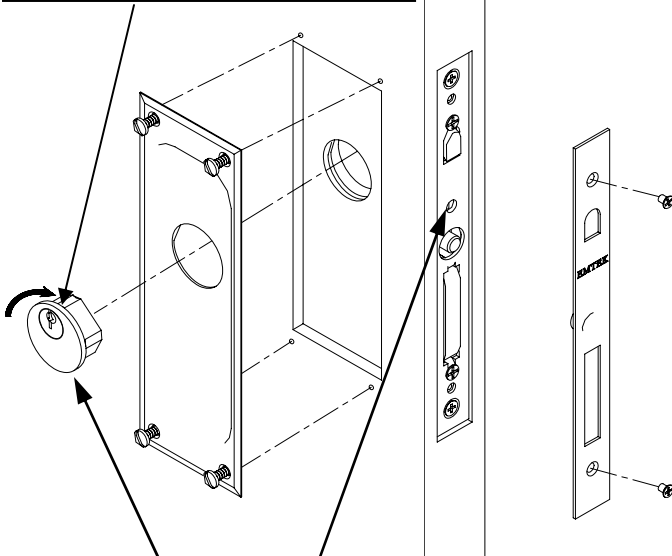

Thread Cylinder into lock body & tighten screw
Counter clockwise to engage notches on cylinder.
NOTE: DO NOT OVER TIGHTEN SCREW.

Door Jamb

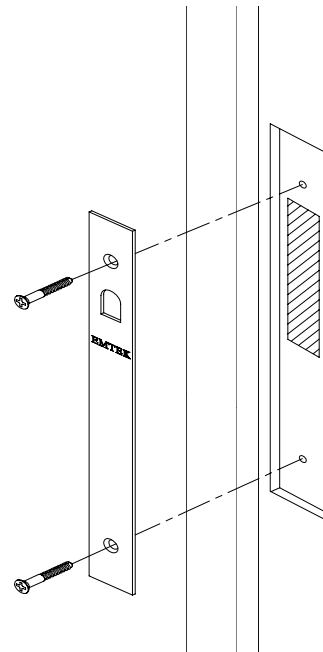

Drill pilot holes for wood screws (provided).